



RESPIRONICS INC.[®]

1001 Murry Ridge Lane
Murrysville, Pennsylvania
15668-8550 USA

RESPIRONICS[®]

Deutschland
Gewerbestrasse 17
82211 Herrsching Germany



0123

1003564
LK 10/19/99

Virtuoso[®] LX
Smart CPAP System

*Operating
Instruction Manual*

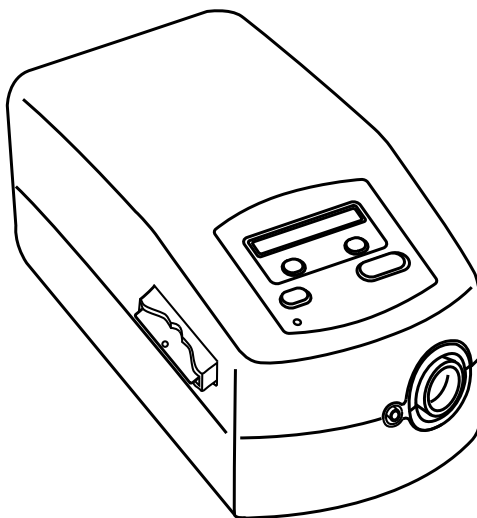

RESPIRONICS[®]

TABLE OF CONTENTS

Unpacking the System	3
Introduction	4
Warnings & Cautions	5
System Features	6
First Time Setup	8
Installing the Filters	9
Setting the Ramp	11
Setting the Alert Tone	12
Setting the Altitude	12
FOSQ Test	13
SmartCard	13
Assembling the Circuit	14
Accessories	15
Adding a Humidifier	15
Adding Oxygen	15
Using DC Power	16
Carrying Case	16
Routine Use	17
Connecting the Circuit	17
Adjusting the Circuit	18
Using the Ramp / Reset Button	18
Turning the System Off	18
Helpful Hints	18
Screen Messages	19
Traveling with the System	21
Routine Maintenance	22
Filters	22
Cleaning	23
Reordering	23
Service	23
Maintenance Record	24
Troubleshooting	25
Specifications	27
Warranty	28

A warranty/comment card should be included with this manual for your completion. If it is not, contact Respironics' Warranty Administrator at 1-800-666-2901 (US and Canada) or 1-412-731-2100 to register your equipment and receive a FREE package of filters.

The Virtuoso LX Smart CPAP device carries a two-year warranty. See the "Warranty" section of this manual for details. You can extend this warranty period to three years for \$39.95. See the warranty/comment card for details or call Respironics' Warranty Administrator.

For Information on Sleep Disorders Contact:

**American Sleep Apnea Association
2025 Pennsylvania Ave., N.W., Suite 905
Washington D.C. 20006
Telephone: 1-202-293-3650**

**National Sleep Foundation
1367 Connecticut Ave., N.W., Suite 200
Washington D.C. 20036
Telephone: 1-202-785-2300**

Virtuoso LX Smart CPAP System is the subject of U.S. patents #5203343, #5239995, and other pending U.S. and foreign patents.

Great Performers and Virtuoso are trademarks of Respironics, Inc.

© Respironics, Inc. 1999

UNPACKING THE SYSTEM

After unpacking the System, check to make sure you have everything shown here:

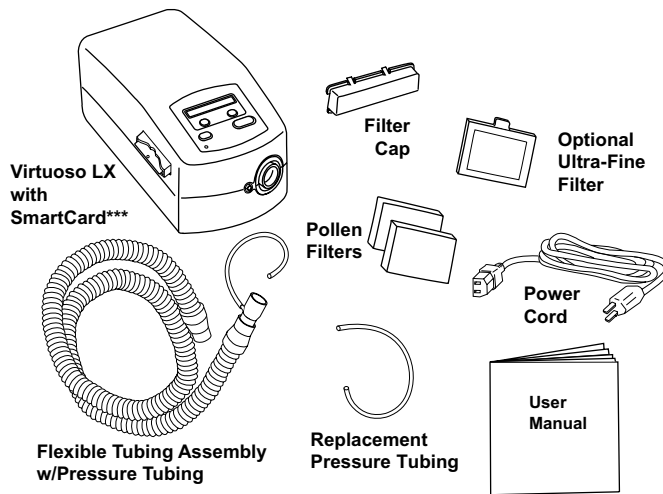

IMPORTANT!

If any of the above parts are missing, contact your home care provider.

Some Virtuoso LX Systems may also include one or more of the following accessories:

- Headgear
- Exhalation Port
- Nasal Mask
- Humidifier
- Carrying Case

***The Encore SmartCard is a feature included with the newest models of the Virtuoso LX, which records the device usage. Another new feature is the FOSQ “Quality of Life” questionnaire. Your doctor or home care provider may ask you to periodically complete this questionnaire and send your answers (recorded on the SmartCard). The FOSQ questionnaire is detailed in the enclosed “Rise and Shine” brochure. If your Virtuoso LX does not have the SmartCard feature, ignore any instructions pertaining to the SmartCard and FOSQ questionnaire.

INTRODUCTION

Intended Use

The Virtuoso® LX Smart CPAP System delivers continuous positive airway pressure (CPAP) therapy for the treatment of adult Obstructive Sleep Apnea (OSA) only. The System offers several options in how therapy is delivered, so treatment can be personalized to meet your needs.

The System can deliver CPAP (Continuous Positive Airway Pressure) therapy or Auto-CPAP therapy. Your home care provider will set the System to the correct mode and make the correct pressure settings. You may also make some adjustments and choose some of your settings.

When set in the Auto-CPAP mode, the System will monitor your breathing as you sleep and automatically adjust the pressure to meet your needs. When set in the CPAP mode, the System will deliver a continuous set pressure during the night. If the ramp function has been prescribed for you, it will allow you to lower the pressure for a preset time period. The lower pressure may help you to fall asleep at a lower, more comfortable pressure.

Several accessories are available to make your OSA treatment with the Virtuoso LX Smart CPAP System as convenient and comfortable as possible. Contact your home care provider to purchase any accessories not included with the Virtuoso LX System.

IMPORTANT!

Read and understand the entire user's manual before operating this System. If you have any questions concerning the use of this System, contact your home care provider or doctor.

Contraindications

Studies have shown that the following pre-existing conditions may contraindicate the use of positive airway pressure therapy for some patients:

- Bullous Lung Disease
- Pathologically Low Blood Pressure
- Pneumothorax
- Pneumocephalus has been reported in a patient using nasal Continuous Positive Airway Pressure. Caution should be used when prescribing CPAP for susceptible patients such as those with: cerebral spinal fluid (CSF) leaks, abnormalities of the cribriform plate, prior history of head trauma, and/or pneumocephalus. (Chest 1989; 96:1425-1426)

The use of positive airway pressure therapy may be temporarily contraindicated if you exhibit signs of a sinus or middle ear infection. Contact your physician if you have any questions concerning your therapy.

WARNINGS & CAUTIONS

WARNING!

Indicates the possibility for injury to the user or the operator.

- DO NOT use any circuit tubing other than the Respirationics six-foot (1.83 m) flexible tubing assembly with the Virtuoso LX System. DO NOT change the length of this tubing or use alternate tubing. This will interfere with the System's operation and may lead to inappropriate therapy.
 - This device is intended for adult use only.
 - This device is not intended for life support.
 - Most CPAP devices have the potential to allow rebreathing of exhaled air. To reduce this potential, observe the following:
 - Use only Respirationics circuit accessories.
 - Do not wear the mask and headgear for more than a few minutes while the unit is not operating.
 - Do not block or try to seal the vent holes in the exhalation port.
- As with most CPAP devices: At low CPAP pressures, some exhaled gas (CO₂) may remain in the mask and be rebreathed.
- Under certain conditions, the temperature of the air flow from this device can be as much as 18° F (10° C) higher than the air temperature in the room. Caution should be exercised if the room temperature is warmer than 90° F (32° C).
 - This equipment is not suitable for use in the presence of a flammable anesthetic mixture in combination with oxygen or air.
 - This equipment is not suitable for use in the presence of nitrous oxide.
 - To avoid electrical shock, disconnect the power cord before cleaning. DO NOT immerse the Virtuoso LX into any fluids.
 - The instructions in this manual are not intended to supersede established medical protocols.
 - Contact your doctor if symptoms of sleep apnea recur.

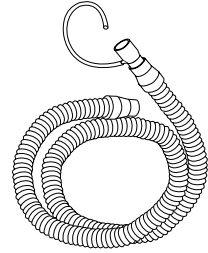

CAUTION!

Indicates the possibility of damage to the device.

- **U.S. federal law restricts this device to sale by or on the order of a physician.**
- Should the noise level of the Virtuoso LX change to include unusual or harsh sounds during operation, discontinue use and contact your home care provider.
- Discontinue using the Virtuoso LX if any of the parts are damaged. Replace any damaged parts before continuing use.
- Tobacco smoke may cause tar buildup within the Virtuoso LX that may result in the device malfunctioning.

Additional warnings and cautions are located throughout this manual as they apply.

SYSTEM FEATURES

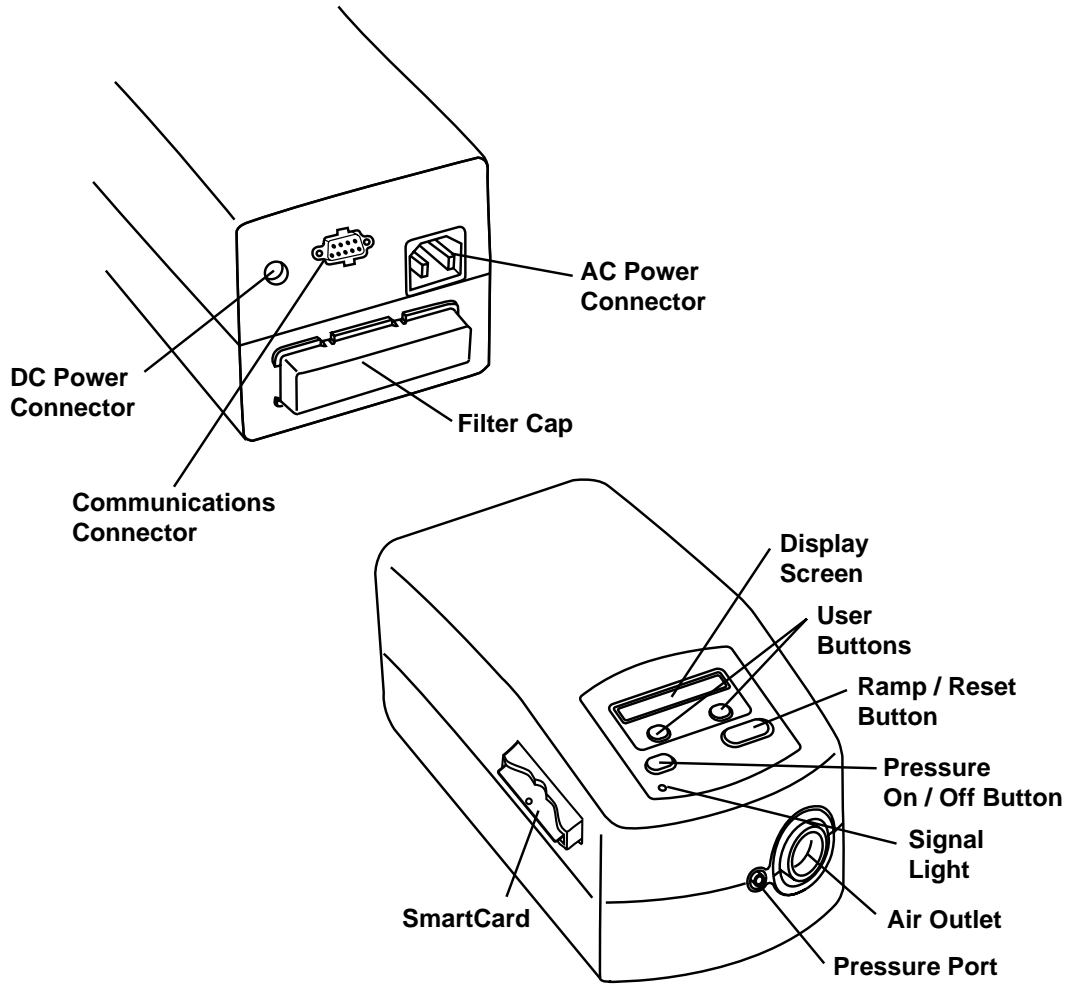

SYSTEM FEATURES

- AC Power Connector** Connect the power cord here.
- Air Outlet** Connect the flexible tubing assembly here.
- Communications**
- Connector** For clinical use with the Encore® Data Management Software. Connect the communications cable here.
- DC Power Connector** Connect the optional DC power cord here.
- Display Screen** All System settings, total operating time, and therapy hours will be displayed here.
- Filter Cap & Filters** The pollen filter screens out normal household dust and pollens. This must be in place at all times when the Virtuoso LX is operating. An optional, ultra-fine filter is also included for more complete filtration of very fine particles. The filter cap can be positioned to direct the air flow away from your bedside.
- Flexible Tubing Assembly** This tubing connects to the Virtuoso LX and the mask to deliver the air flow to the user. The flexible tubing is permanently adhered to the tubing swivel. (not shown)
- Pressure On / Off**
- Button** This button turns the air flow on or off.
- Power Cord** IEC 320 Style (not shown)
- Pressure Port** Connect the pressure tubing here.
- Ramp / Reset Button** This button decreases the pressure to the minimum pressure setting.
- Signal Light** The green light signals when the Virtuoso LX is ready for use. The light will go out when the air flow is turned on. A flashing light signals that the Virtuoso LX needs to be serviced.
- SmartCard** The SmartCard records device usage information (e.g., a history of pressure settings and times the system was used for therapy). Contact your home care provider for further information about the SmartCard.
- User Buttons** These buttons can be used to change some of the System settings.

Medical Product Note: For ease at airport security stations, there is a note on the bottom of the Virtuoso LX stating that it is medical equipment. It may help if you also take this manual with you when you travel.

FIRST TIME SETUP

WARNING!

DO NOT use the Virtuoso LX CPAP System until an appropriate professional adjusts the settings!

To use the System, you will need the following accessories in order to assemble the recommended circuit. To order any accessories not included with the Virtuoso LX, contact your home care provider.

- Respironics 6 ft. (1.83 m) Flexible Tubing Assembly
- Nasal Mask
- Whisper Swivel® Exhalation Port
- Headgear

WARNING!

DO NOT connect any equipment to the Virtuoso LX unless recommended by Respironics or your doctor.

WARNING!

DO NOT use the Respironics NRV-2 or similar exhalation ports.

WARNING!

Respironics circuit accessories (i.e., nasal mask, exhalation port, flexible tubing assembly, and Comfort Flap®) are for single patient use only and are not intended to be used on multiple patients.

CAUTION!

If the Virtuoso LX has been exposed to either very hot or very cold temperatures, allow the device to adjust to room temperature (approximately 2 hours) before beginning setup.

ATTENTION!

The SmartCard does not need to be installed for the Virtuoso LX to work properly. The SmartCard records device usage information for use by your home care provider. Contact your home care provider if you have any questions about the SmartCard.

Installing Filters

1. Install the filters in the back of the Virtuoso LX.

The pollen filter must be in place at all times when the Virtuoso LX is operating. The white ultra-fine filter is optional and can be used in addition to the pollen filter. The ultra-fine filter is recommended for people who are sensitive to tobacco smoke or other small particles.

a. **Place one of the pollen filters over the ultra-fine filter.** Or, if you are not using the ultra-fine filter, simply place the pollen filter into the filter area on the back of the Virtuoso LX. An extra pollen filter is included for your convenience.

b. **Attach the filter cap.** Position the opening on the side of the cap so that it is facing away from the bedside. Insert the cap's bottom tabs into the openings below the filter area. Press down on the cap's top tabs and insert them into the openings above the filter area.

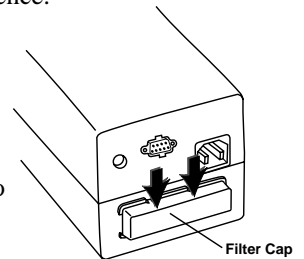

Power Cord

2. Connect the power cord.

Plug the socket end of the power cord into the AC power connector on the back of the Virtuoso LX.

Plug the pronged end of the power cord into an electrical outlet.

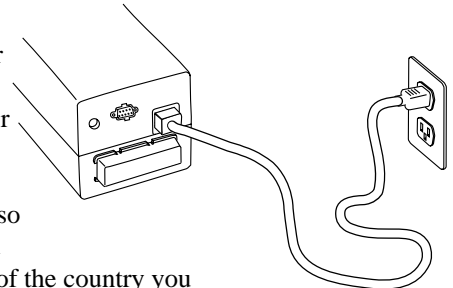

IMPORTANT!

An international plug adapter may also be required to make your power cord compatible with the electrical outlet of the country you are in. If further assistance is required, contact Respironics International Customer Service department at 1-800-345-6443 (US and Canada) or 1-412-731-2100.

CAUTION!

Inspect the power cord often for any signs of damage. Replace a damaged cord immediately.

CAUTION!

The Virtuoso LX is activated when the power cord is connected. The pressure on/off button only turns the blower on/off.

FIRST TIME SETUP

After the Virtuoso LX is plugged into an electrical source, it will perform a brief self-diagnostic test. The following message will then appear on the display screen.

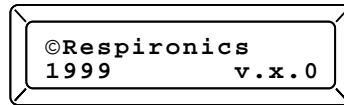

IMPORTANT!

DO NOT use the Virtuoso LX if the display is erratic. Contact your home care provider for further instructions.

IMPORTANT!

DO NOT turn the air flow on until the circuit tubing is connected.

Device Settings

3. Follow the display screens to change the system settings.

IMPORTANT!

Make sure the air flow is turned OFF. You cannot change any settings while the Virtuoso LX's air flow is turned ON.

- a. The blower status will be displayed and the green signal light will be on. **Press the button below "Menu."**

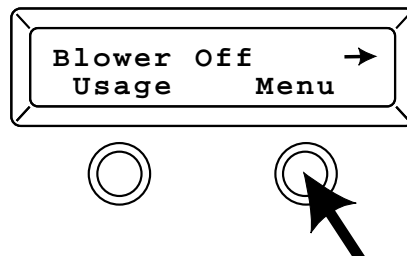

- b. A message will display asking if you want to change the settings. **Press the button below "Yes."**

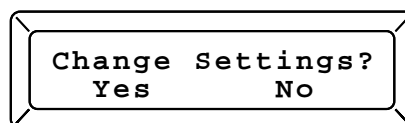

If you press "No," go to page 13 for instructions.

The Ramp Feature

If your System is set in the CPAP mode and your physician prescribed ramp for you, the ramp setting will be displayed. If ramp has not been prescribed for you or your System is set in the Auto-CPAP mode, go to Step d.

The Ramp feature will reduce the pressure and then gradually increase (ramp) the pressure to the prescription pressure setting so that you can fall asleep more comfortably.

Setting the Minimum Ramp Pressure

- c. The minimum ramp pressure will be displayed. Your home care provider will have already set a minimum ramp pressure. If you feel the minimum ramp pressure is set too low or too high, you can change the setting. (Range: 4 cm H₂O - Prescription Pressure)

If the minimum ramp pressure is correct, press the button below “Yes.”

To change the pressure in 1 cm H₂O increments, press the button below “+1” until the desired pressure is displayed. Press the button below “Yes” to confirm the setting.

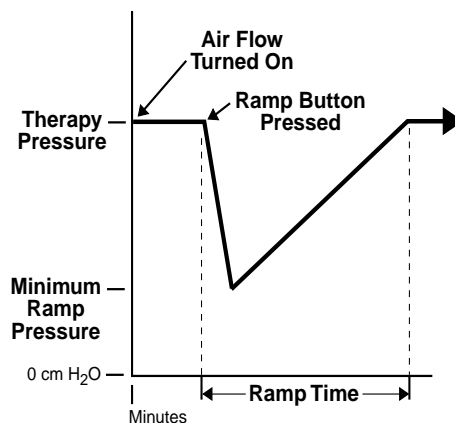
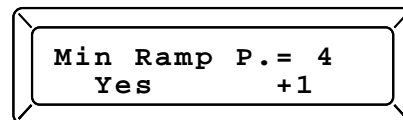

FIRST TIME SETUP

Turning the Alert Tone On or Off

- d. The audible mask alert is a beeping sound that the Virtuoso LX makes when a large, continuous air leak has been detected in the circuit. You have the option of turning the alert tone on or off.

IMPORTANT!

The Mask Alert is a convenience feature that may not work at extreme altitudes or with some mask types or circuit configurations (i.e., pass-over humidifier, full face mask). This will not adversely affect the therapy you receive from the System.

If the setting is correct, press the button below “Yes.”

To change the setting, press the button below “No.”

Press the button below “Yes” to confirm the setting.

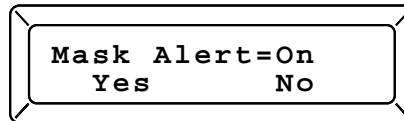

The new Virtuoso LX Systems (with SmartCard) have been enhanced to include automatic altitude adjustment. IF YOU HAVE A NEWER MODEL VIRTUOSO LX (WITH SMARTCARD) NO ALTITUDE SETTINGS ARE REQUIRED.

If your Virtuoso LX is not equipped with a SmartCard, continue to Step e.

Setting the Altitude

- e. The altitude setting will be displayed. To ensure proper therapy, this setting needs to be accurate for your current location. When traveling, make sure you verify the altitude of your destination (possibly with the local library) and change the setting accordingly. The Virtuoso LX has three altitude settings;

LOW 0-1800 ft. (0-548 m)

MID 1801- 3600 ft. (549-1097 m)

HIGH 3601 - 5500 ft. (1098-1677 m)

If the altitude is correct, press the button below “Yes.”

To change the altitude, press the button below “No” until the correct altitude is displayed. Press the button below “Yes” to confirm the setting.

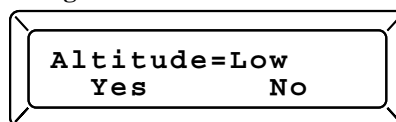

IMPORTANT!

Altitudes above 5500 ft. (1677 m) may affect the accuracy of the pressure setting. Have the home care provider verify the pressure settings with a water column manometer.

FIRST TIME SETUP

FOSQ Test

When “Change Settings” is displayed, if you press the button below “No,” a screen will appear that says “FOSQ Test?” .

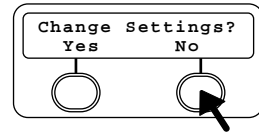

The FOSQ test is a “quality of life” questionnaire designed specifically for people with sleep disorders. The results allow health care professionals to see how therapy has improved the quality of your life. By completing the questionnaire periodically, you can provide valuable information about the effectiveness of your treatment. The Virtuoso LX has the ability to record your answers on the SmartCard for later review by the health care provider. Contact your home care provider for further instructions.

IMPORTANT!

If your doctor or home care provider instructs you to complete the questionnaire, he will provide you with the instructions and the questions and you will enter your answers into the Virtuoso LX. Make sure the SmartCard is installed before answering the questions.

A message will display asking if you want to take the FOSQ test. If you want to take the test, Press the button below “Yes.”

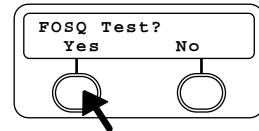

If you do not want to take the test, press the button below “No” and the display will go back to the main screen.

SmartCard

A SmartCard is installed in the side of the Virtuoso LX to record information for the home care provider. Your home care provider may ask you to periodically remove the SmartCard and mail it to him for evaluation.

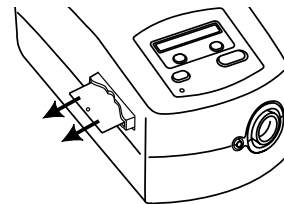

The arrow in the upper right corner of the display screen signifies that the SmartCard is installed properly.

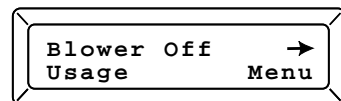

FIRST TIME SETUP

Assembling the Circuit

4. **Assemble the circuit.** To use the System, you will need the following accessories in order to assemble the recommended circuit.

- **Respironics 6 ft. (1.83 m) Flexible Tubing Assembly**
- **Nasal Mask**
- **Whisper Swivel® Exhalation Port**
- **Headgear**

WARNING!

DO NOT use the Respironics NRV-2 or similar exhalation ports.

WARNING!

DO NOT use the Respironics Monarch® Mini Mask when the Virtuoso LX is set in the Auto-CPAP mode.

WARNING!

If the Virtuoso LX is used for multiple persons (e.g., rental devices) a low-resistance, main flow bacteria filter should be installed in-line between the Virtuoso LX and the circuit tubing. Appropriate diagnostic pressures must be determined when a bacteria filter and other optional circuit accessories are in place.

- a. Connect the tubing swivel to the air outlet on the front of the Virtuoso LX.

Connect the pressure tubing to the pressure port on the front of the Virtuoso LX.

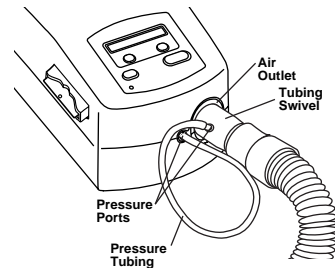

- b. Connect the exhalation port to the end of the flexible tubing.

Position the exhalation port so that the vented air is blowing away from your face. Connect the mask's connector to the exhalation port.

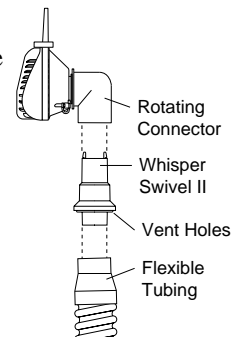

Contact your home care provider for additional information on the accessories available for the Virtuoso LX System.

Adding a Humidifier The Oasis™ humidifier may reduce nasal dryness and irritation by adding moisture to the air flow.

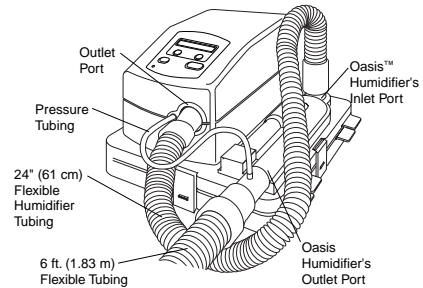

CAUTION!

The Respirationics Oasis humidifier is the only in-line humidifier recommended for use with the Virtuoso LX System. Use of another humidifier may lead to improper therapy.

CAUTION!

When using the Oasis humidifier, always disconnect the humidifier tubing from the Virtuoso LX System when it is turned off. **DO NOT** use a room humidifier within six feet (1.83 m) from the Virtuoso LX. Moisture can build up in the System and cause damage. Follow the instructions included with the humidifier.

IMPORTANT!

The Mask Alert, Auto-on, and Auto-off are convenience features that may not work at extreme altitude levels or with some mask types or circuit configurations (i.e., pass-over humidifier, full-face mask). If this occurs, press the Pressure On/Off button on the Virtuoso LX to turn the air flow on or off. This will not adversely affect the therapy you receive from the System.

Adding Oxygen to the System

Please note the warnings listed below when using oxygen with the Virtuoso LX System.

WARNING!

When using oxygen with the Virtuoso LX System, turn the Virtuoso LX on before turning the oxygen on. Turn the oxygen off before turning the Virtuoso LX off. This will prevent oxygen accumulation in the Virtuoso LX.

WARNING!

Oxygen accelerates fires. Keep the Virtuoso LX and the oxygen container away from heat, open flames, or other sources of ignition. **DO NOT** smoke in the area near the Virtuoso LX or the oxygen.

ACCESSORIES

Using a DC Power System

You can also use the Virtuoso LX in a stationary recreational vehicle, boat or motor home with a 12 volt DC power source. The Virtuoso LX should not be operated while the vehicle is in motion. Contact your home care provider for additional information.

CAUTION!

Only use the Respironics DC Power System available from your home care provider. Use of any other system may cause damage to the Virtuoso LX or your vehicle.

CAUTION!

DC Power is not intended to be used as battery back-up. DO NOT connect the DC Power System while the Virtuoso LX is operating on AC power. System damage may occur.

Carrying Case

The carrying case holds the Virtuoso LX and accessories. When traveling by airplane, the carrying case is for carry-on luggage only. Never check the Virtuoso LX through the baggage department.

Connecting the Circuit

IMPORTANT!

1. Connect the circuit.

Before each use, examine the flexible tubing, the tubing swivel, and the pressure tubing for any damage or debris. Replace any damaged tubing.

- a. Connect the mask to the headgear, following the instructions included with the headgear.
- b. **If your home care provider has selected the Auto-On feature for you**, put on the mask and headgear, and breathe normally through your nose. The air flow should automatically turn ON when you begin breathing through the circuit. If the air flow does not turn on within four breaths, turn it ON by pressing the Pressure On/Off button on the top of the Virtuoso LX. When operating the System with some mask types, some circuit configurations, or at higher altitudes, the air flow may NOT automatically turn on.

- or -

- b. **If your home care provider has not selected the Auto-On feature for you**, put on the mask and headgear, and immediately turn the air flow ON by pressing the Pressure On/Off button on the top of the Virtuoso LX. Breathe normally through your nose.

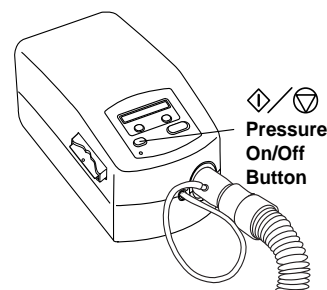

IMPORTANT!

If the Virtuoso LX is set in the Auto-CPAP mode, “Leak Test” will appear on the display screen. **This screen will not appear if the Virtuoso LX is set in the CPAP mode.**

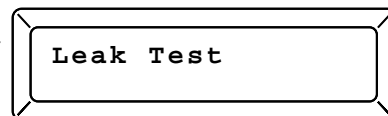

During this time, the Virtuoso LX will deliver moderate air pressure for one (1) minute so that you can adjust your mask properly and check for any leaks in the circuit. The air pressure will then change to the minimum pressure. You can reduce the air flow to the lower pressure at any time during the leak test by pressing the Ramp / Reset button.

ROUTINE USE

Adjusting the Circuit

2. Adjust the circuit.

- a. Lie down on your bed and adjust the flexible tubing so it is free to move if you turn in your sleep.
- b. Adjust the mask and headgear until you have a comfortable fit and there are no air flow leaks into your eyes.

When the air flow is on, the green signal light will go out. The word “Menu” will no longer be displayed, and the pressure setting will now be shown.

Using the Ramp / Reset Button

Pressing the Ramp / Reset button at any time will reduce the pressure to the minimum pressure setting.

- **Auto-CPAP Mode** - Pressing the button will reduce the pressure and then automatically increase the pressure during the night to the appropriate level to meet your needs.
- **CPAP Mode** - If your physician prescribed ramp for you, pressing the button will reduce the pressure and then gradually increase (ramp) the pressure to the therapeutic pressure setting so that you can fall asleep more comfortably. Note: *The ramp feature is not prescribed for all users.*

- #### 3. Press the Ramp / Reset button on the top of the Virtuoso LX. You can use the Ramp / Reset button as often as you wish during the night.

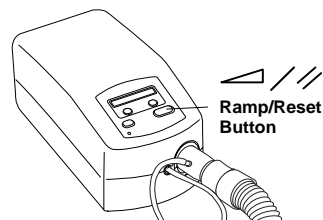

Turning the System OFF

- #### 4. Remove the mask and headgear.
- The air flow will automatically turn off (in less than 1 minute). If the audible mask alert is turned on, the alert tone will sound (in less than 45 seconds after you remove the mask).

IMPORTANT!

The Auto-off feature may have been disabled by your home care provider. Press the Pressure On / Off button on the top of the Virtuoso LX to turn the air flow OFF.

Helpful Hints

- If the alert tone sounds, press any button on the Virtuoso LX to silence the alert tone. Refer to the “Screen Messages” section of the manual for further instructions.
- If you want to talk after putting on the mask, and ramp or Auto-CPAP has been prescribed for you, use the Ramp/Reset button to reduce the pressure. This will make talking easier.
- Make sure that bedding, curtains, or other items are not blocking the filter or vents of the Virtuoso LX. Air must flow freely around the Virtuoso LX for the System to work properly.
- If the air flow from the Virtuoso LX feels cold, reposition the circuit tubing so that it runs under your bed covers to reduce heat loss while you sleep.

Screen Messages

During use, any of five messages may be shown on the Virtuoso LX display screen.

1. “Mask Alert” - A large circuit leak, such as mask removal, has been detected.

What will happen:

- The air flow will turn off in approximately 2 minutes (if the auto-off feature has been turned on).
- The alert tone will sound in less than 45 seconds (if the mask alert feature has been turned on).

What to do:

- Press any button on the Virtuoso LX to silence the alert tone and clear the display screen.
- Check the circuit (flexible tubing, pressure tubing, mask) for any leaks and adjust the mask and headgear.
- Press the Pressure On / Off button to restart the air flow.

IMPORTANT!

The audible mask alert setting can be turned on or off. See the “First Time Use” section for instructions.

2. “Connect Pressure Line” - The flexible tubing and/or pressure tubing has become disconnected from the System.

What will happen:

- The air flow will turn off and the alert tone will sound within 20 seconds.

What to do:

- Press any button on the Virtuoso LX to silence the alert tone and clear the display screen.
- Reconnect the tubing to the air outlet.
- Press the Pressure On / Off button to restart the air flow.

IMPORTANT!

This alert setting cannot be turned on or off.

ROUTINE USE

Screen Messages

3. **“System Error ####” - The Virtuoso LX is not functioning correctly and may need servicing.**

What will happen:

- The air flow will turn off immediately.
- The alert tone will sound.
- The signal light will flash on and off.

What to do:

- Reset the Virtuoso LX by unplugging the power cord from the electrical outlet and then plugging it in again.
- If the message appears again, contact your home care provider or Respironics for directions on having the Virtuoso LX serviced. Please have the serial number of the Virtuoso LX and the error code ready when you call.

This alert setting cannot be turned on or off.

IMPORTANT!

4. **“Remote Connected” - This message will appear during clinical use only.**

5. **“Leak Test” - Auto-CPAP mode only - The Virtuoso LX has increased the air flow pressure for one (1) minute so that you can adjust the mask properly and check for any leaks in the circuit.**

What will happen:

- When the test is completed, the main screen will be displayed with the current pressure.

What to do:

- No action is required.
- If desired, press the Ramp / Reset button to reduce the air flow pressure to the minimum setting before the minute is over.

6. **“→” - The SmartCard is in place.**

7. **“Remove Card” - The Encore SmartCard has been inserted improperly.**

What to do:

- Remove the SmartCard. Reinsert the SmartCard making sure that the printed side of the card is facing up and the end with the arrow goes into the device first.
- If the message appears again, remove the card and contact your home care provider to have the SmartCard replaced. You can continue to use the Virtuoso LX. Removing the SmartCard will not affect the performance of the Virtuoso LX.

TRAVELING WITH THE SYSTEM

Packing the System

When traveling, the optional carrying case is for carry-on luggage only. The carrying case will not protect the System if it is put through checked baggage.

Security Stations

For ease at security stations, there is a note on the bottom of the Virtuoso LX stating that it is medical equipment.

It may be helpful to bring this manual along with you to help security personnel understand the Virtuoso LX.

Checking the Power Cord

If you are traveling to a country with a line voltage different than the one you are currently using, an international plug adapter may be required to make your power cord compatible with the power outlets of the country to which you are traveling.

IMPORTANT!

For more information, contact Respironics International Customer Service department at 1-800-345-6443 (US and Canada) or 1-412-731-2100.

ROUTINE MAINTENANCE

Cleaning and Replacing the Filters

The **gray pollen filter** should be cleaned at least once every two weeks under normal usage and replaced with a new one every six months. The **white ultra-fine filter** is disposable and should be replaced after 30 nights of use or sooner if it appears dirty. **DO NOT** clean the ultra-fine filter.

CAUTION!

Operating the Virtuoso LX with a dirty filter may keep the system from working properly and damage the Virtuoso LX.

1. Remove the filter cap by gently pressing down on the two latches on the top of the filter cap.

2. Change the filters.

a. Remove the filter(s) from the Virtuoso LX. Rinse the gray pollen filter in a steady stream of running water. Squeeze out the water and repeat. Air dry on a rack for 8 to 12 hours or in a clothes dryer for 15 to 20 minutes.

If you are using the white ultra-fine filter, and it appears dirty, discard the filter and replace it with a new one.

b. Place the white ultra-fine filter under the clean pollen filter. Insert the filter(s) into the filter area on the back of the Virtuoso LX.

CAUTION!

Never install a wet filter into the Virtuoso LX. We recommend that you clean the filter in the morning and alternate using the two pollen filters provided with the System to ensure enough drying time for the cleaned filter.

3. Replace the filter cap.

ROUTINE MAINTENANCE

Cleaning the System

WARNING!

To avoid electrical shock, unplug the Virtuoso LX before cleaning. **DO NOT** immerse the Virtuoso LX into any fluids.

1. Disconnect the pressure tubing from the tubing swivel. Disconnect the tubing swivel from the air outlet.
2. Wipe the outside of the Virtuoso LX and the pressure tubing with a cloth slightly dampened with water and a mild detergent. **DO NOT IMMERSE THE PRESSURE TUBING INTO ANY FLUIDS.** Let the Virtuoso LX dry before plugging in the power cord.
3. Gently wash the flexible tubing and the tubing swivel in a solution of warm water and a mild detergent. Rinse thoroughly. Air dry.
4. Inspect the Virtuoso LX and all circuit parts for any damage after cleaning. Replace any damaged parts.

Reordering

Contact your home care provider to order accessories or replacement filters.

Service

The Virtuoso LX System does not require routine servicing.

- If you feel the Virtuoso LX is not performing properly or delivering the correct air pressure, contact your home care provider or Respironics.
- If the noise level of the Virtuoso LX has changed to include unusual or harsh sounds during operation, contact your home care provider for directions on having the Virtuoso LX serviced.

WARNING!

If the Virtuoso System malfunctions, contact your home care provider immediately. Never attempt to open the Virtuoso LX's enclosure.

If you need technical assistance, call:

Respironics' Technical Service Department
1-800-345-6443 (US and Canada) or 1-412-731-2100

ROUTINE MAINTENANCE

Maintenance Record

Filter Replaced
 Mask Replaced
 Pressures Checked
 Memory Downloaded
 Memory Reset
 Therapy Hours
 Total Operation Time*

Total Operation Time*

* To display the total operation time, press the button below “Usage.” The usage hours will be displayed for 10 seconds and then return to the main screen.

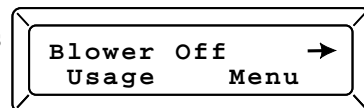

Total Operation Time Display

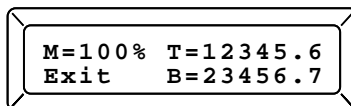

- M =** The amount of memory space available. The SmartCard records device usage information (e.g., a history of pressure settings; number of times the system was used for therapy). Some physicians and home care providers record this information. When “M=000%” is displayed, contact your home care provider if he/she has asked you to monitor the SmartCard’s memory level. If “M=!!!” is displayed, contact your home care provider for servicing. If “M=---%” is displayed, the SmartCard is not installed.
- T =** The therapy hours are the total number of hours the Virtuoso LX has operated with the air flow turned on. Like a trip meter in a car, the therapy hours can be reset to zero by the home care provider.
- B =** The total blower time is the total number of hours the Virtuoso LX has been in use. This total includes factory testing time.
- Exit =** Returns the display to the main screen.

TROUBLESHOOTING

The table below lists troubleshooting solutions to common problems you may have with the Virtuoso LX System. If none of the corrective actions solve the problem, contact your home care provider or Respironics.

Problem

Solutions

The “Mask Alert” message appears on the display screen and the alert tone is sounding.

Press any button on the Virtuoso LX to silence the alert tone and clear the display screen. The Virtuoso LX has detected a large leak in the circuit or you have taken the mask off without turning the air flow off. Check the circuit connections for leaks.

The “Connect Pressure Line” message appears on the display screen and the alert tone is sounding.

Press any button on the Virtuoso LX to silence the alert tone and clear the display screen. The tubing has become disconnected from the System. Reconnect the tubing.

Pressing the Ramp/Reset button does not reduce the air pressure.

Contact your home care provider. Ramp may not have been prescribed for you. Make sure the ramp pressure setting is lower than the CPAP pressure setting.

The air flow from the Virtuoso LX seems warm.

Replace or clean the filter. Make sure the Virtuoso LX is away from bedding or curtains that could block the flow of air around the Virtuoso LX. Make sure the Virtuoso LX is away from heating equipment (e.g., forced air vents, radiators).

The memory display reads “M=000%.”

The Virtuoso LX records patient usage information (e.g., a history of pressure settings, times the system was used for therapy). Some physicians and home care providers record this information to assist in your CPAP treatment. When “000%” is displayed, contact your home care provider if he/she has asked you to monitor the memory level. Information will still be recorded once “000%” is displayed.

The “Remove Card” message appears on the display screen.

The Encore SmartCard has been inserted improperly. Remove the SmartCard. Reinsert the SmartCard making sure that the printed side of the card is facing up and the end with the arrow goes into the device first. If the message appears again, contact your home care provider or Respironics for directions on having the Virtuoso LX serviced. Please have the serial number of the Virtuoso LX and the error code ready when you call.

TROUBLESHOOTING

Problem

Solutions

The air flow will not automatically turn ON or OFF.

The Auto-on, Auto-off, and Mask Alert are convenience features that may not work with some mask types, circuit configurations, or at extreme altitudes. This will not adversely affect the therapy received from the System. The Auto-on and Auto-off settings may have been disabled by your home care provider.

The Virtuoso LX is making a faint humming sound when the air flow is turned off.

This is a normal characteristic of the Virtuoso LX.

The Virtuoso LX will not turn on.

Make sure that the Virtuoso LX is plugged into a working outlet. Contact your home care provider or Respironics.

The Mask Alert is not working.

In the settings menu, make sure the display reads “Mask Alert=On.” The Mask Alert is a convenience feature that may not work with some mask types, circuit configurations, or at extreme altitudes. This will not adversely affect the therapy received from the System.

The air pressure seems higher than usual.

Check the altitude setting and make sure the setting is correct for your area. If the pressure is still incorrect, contact your home care provider or Respironics for directions on having the Virtuoso LX serviced. Please have the serial number of the Virtuoso LX ready when you call.

The memory display reads “M=!!!.”

The Virtuoso LX may not be operating correctly. Contact your home care provider or Respironics for directions on having the Virtuoso LX serviced. Please have the serial number of the Virtuoso LX ready when you call.

The memory display reads “M=---”

The SmartCard is not installed in the side of the Virtuoso LX. Your home care provider or doctor may have decided that recording the Virtuoso LX’s usage is not important for your therapy.

The “System Error” message appears on the display screen.

The Virtuoso LX may not be operating correctly. Reset the Virtuoso LX by unplugging the power cord from the electrical outlet and then plugging it in again. If the message appears again, contact your home care provider or Respironics for directions on having the Virtuoso LX serviced. Please have the serial number of the Virtuoso LX ready when you call.

SPECIFICATIONS

Device Size

Dimensions: 10.00" x 5.50" x 4.75" (25x14x12 cm)
Weight: 3.5 lbs. (1.6 kg)

Product Use and Storage Environment

	Operation	Transport & Storage
Temperature:	41 - 104° F (5 - 40° C)	-4 - 140° F (-20 - 60° C)
Humidity:	15 - 95% Non-condensing	15 - 95% Non-condensing
Atmospheric Pressure:	82.8 - 102 kPascals	50 - 102 kPascals

Power Requirements

The electrical installation of the relevant room must comply with IEC requirements.

100 - 240 VAC, 50/60 Hz / 12 VDC

Current Consumption: AC 1.0 A max. / DC 3.0 A max.

Type of protection against electric shock: Class II Equipment

Degree of protection against electric shock: Type BF Applied Part

Degree of protection against harmful ingress of water: Ordinary Equipment (IPX0)

Mode of Operation: Continuous

Fuses: There are no user replaceable fuses.

DC Cord Fuse (not included): 3 A, Time Delay, Type MDL

EMC Interference: Meets CISPR II, Class B Emissions Requirements

Mode of Operation: Continuous

Communications Connector: Must be connected to an IEC 950 approved computer.

Symbol Key

 **Pressure ON / OFF**

 **Ramp / Reset**

 **DC Power**

 **Type BF Applied Part**

 **Class II (Double Insulated)**

 **Attention, consult accompanying documents**

 **European CE Marking**

LIMITED WARRANTY

Respironics, Inc.[®] warrants that the Virtuoso[®] LX device shall be free from defects of workmanship and materials and will perform in accordance with the product specifications for a period of two (2) years from the date of sale by Respironics, Inc. to the dealer. If the product fails to perform in accordance with the product specifications, Respironics, Inc. will repair or replace, at its option, the defective material or part. Respironics, Inc. will pay customary freight charges from Respironics, Inc. to the dealer location only. This warranty does not cover damage caused by accident, misuse, abuse, alteration and other defects not related to material or workmanship.

RESPIRONICS, INC. DISCLAIMS ALL LIABILITY FOR ECONOMIC LOSS, LOSS OF PROFITS, OVERHEAD OR CONSEQUENTIAL DAMAGES WHICH MAY BE CLAIMED TO ARISE FROM ANY SALE OR USE OF THIS PRODUCT. SOME STATES DO NOT ALLOW THE EXCLUSION OR LIMITATION OF INCIDENTAL OR CONSEQUENTIAL DAMAGES, SO THE ABOVE LIMITATION OR EXCLUSION MAY NOT APPLY TO YOU.

THIS WARRANTY IS GIVEN IN LIEU OF ALL OTHER EXPRESS WARRANTIES. IN ADDITION, ANY IMPLIED WARRANTIES, INCLUDING ANY WARRANTY OF MERCHANTABILITY OR FITNESS FOR THE PARTICULAR PURPOSE ARE LIMITED TO TWO YEARS. SOME STATES DO NOT ALLOW LIMITATIONS ON HOW LONG AN IMPLIED WARRANTY LASTS, SO THE ABOVE LIMITATION MAY NOT APPLY TO YOU. THIS WARRANTY GIVES YOU SPECIFIC LEGAL RIGHTS, AND YOU MAY ALSO HAVE OTHER RIGHTS WHICH VARY FROM STATE TO STATE.

To exercise your rights under this warranty, contact your local, authorized Respironics, Inc. dealer or Respironics, Inc. at 1001 Murry Ridge Lane, Murrysville, Pennsylvania 15668, 1-800-345-6443 or 1-412-731-2100.

IMPORTANT!

Fill in the information below when you receive the Virtuoso LX System.

Virtuoso LX Serial No.: _____ (Located on the bottom of the unit)

System Prescribed for: _____

Date of Purchase or Rental: _____

Mode of Therapy: ____ Auto-CPAP ____ CPAP Pressure Setting: _____ cm H₂O

Mask Type: _____

Mask Size: _____

Comfort Flap® Nasal Mask Accessory: ____ yes ____ no

If you have any questions concerning the System, contact:

• Home Care Company: _____

Telephone Number: _____

• Doctor: _____

Telephone Number: _____

• Respirationics, Inc.

1001 Murry Ridge Lane

Murrysville, Pennsylvania

15668-8550 U.S.A.

Customer Service

Telephone Number: 1-800-345-6443 (US and Canada) or 1-412-731-2100